

# Guidelines for Rescue Services Passenger Cars

Mercedes-Benz • AMG • McLaren • Maybach • smart



Mercedes-Benz

Sedan



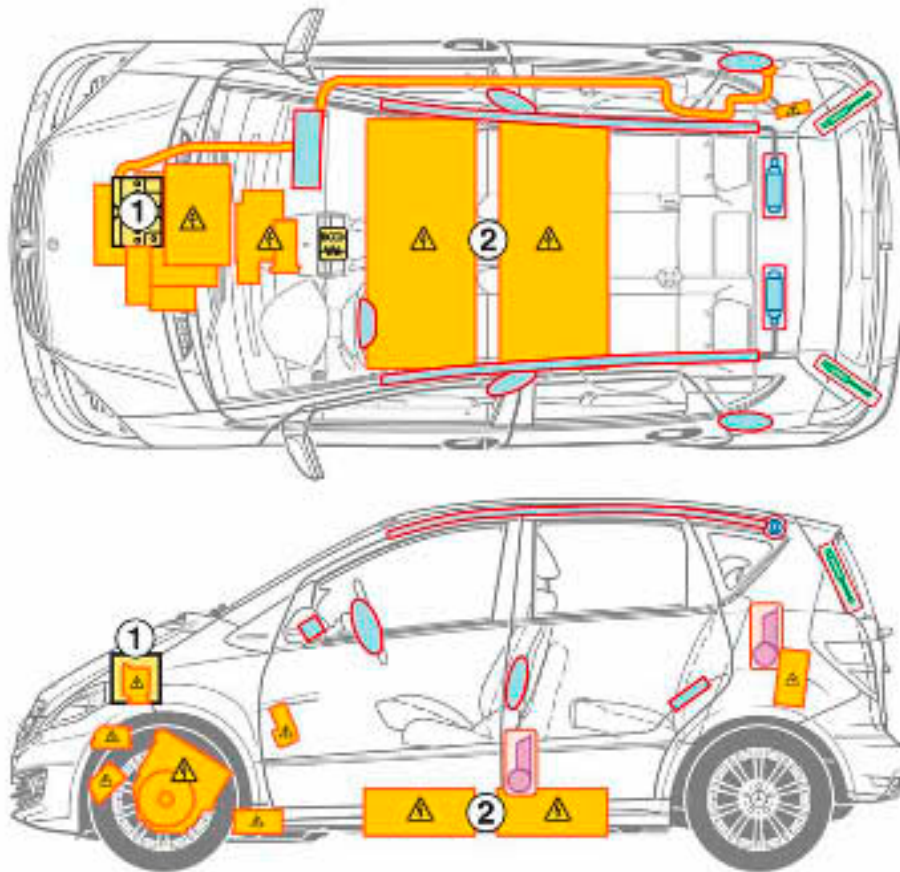





A-Class E-Cell  
(model 169)



1 12 V battery

2 High-voltage battery

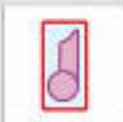
Legend

	Airbag		Body reinforcement		Control unit
	Gas generator		High-voltage components		Battery
	Emergency tensioning retractor		Gas-filled strut		Fuel tank

**B-Class F-Cell  
with fuel cell  
drive**



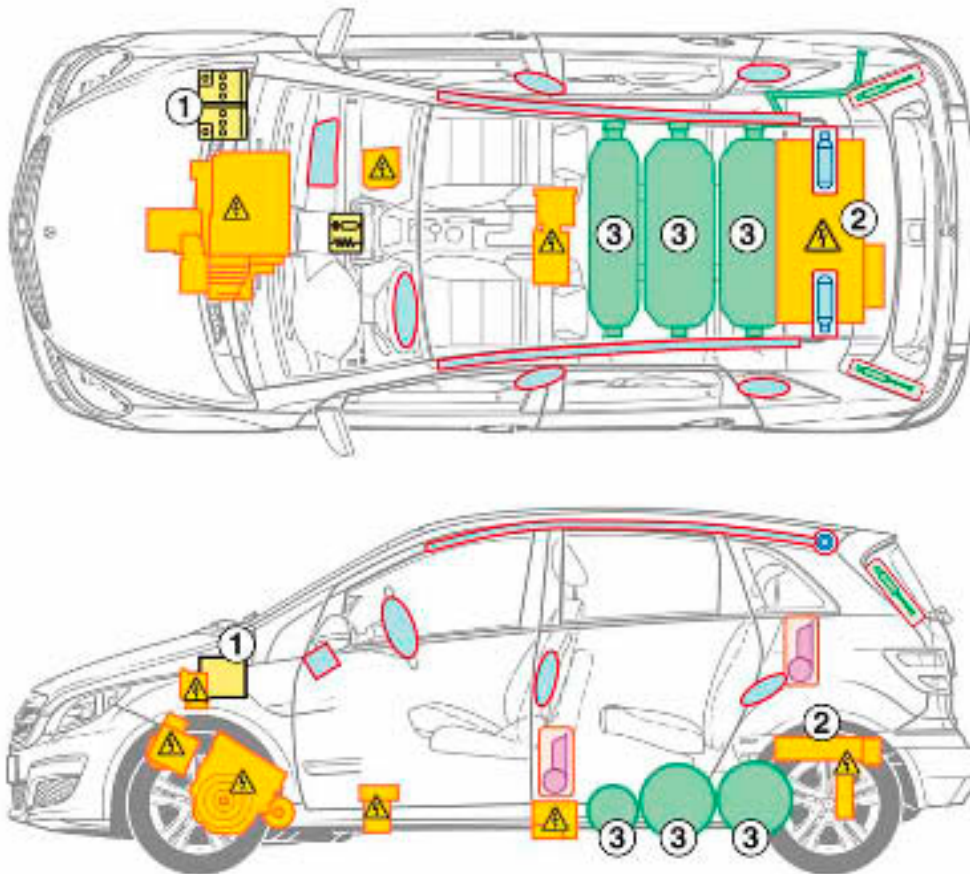





(model 245)



1 12 V battery  
2 High-voltage battery

3 Hydrogen tank

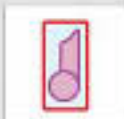
**Legend**





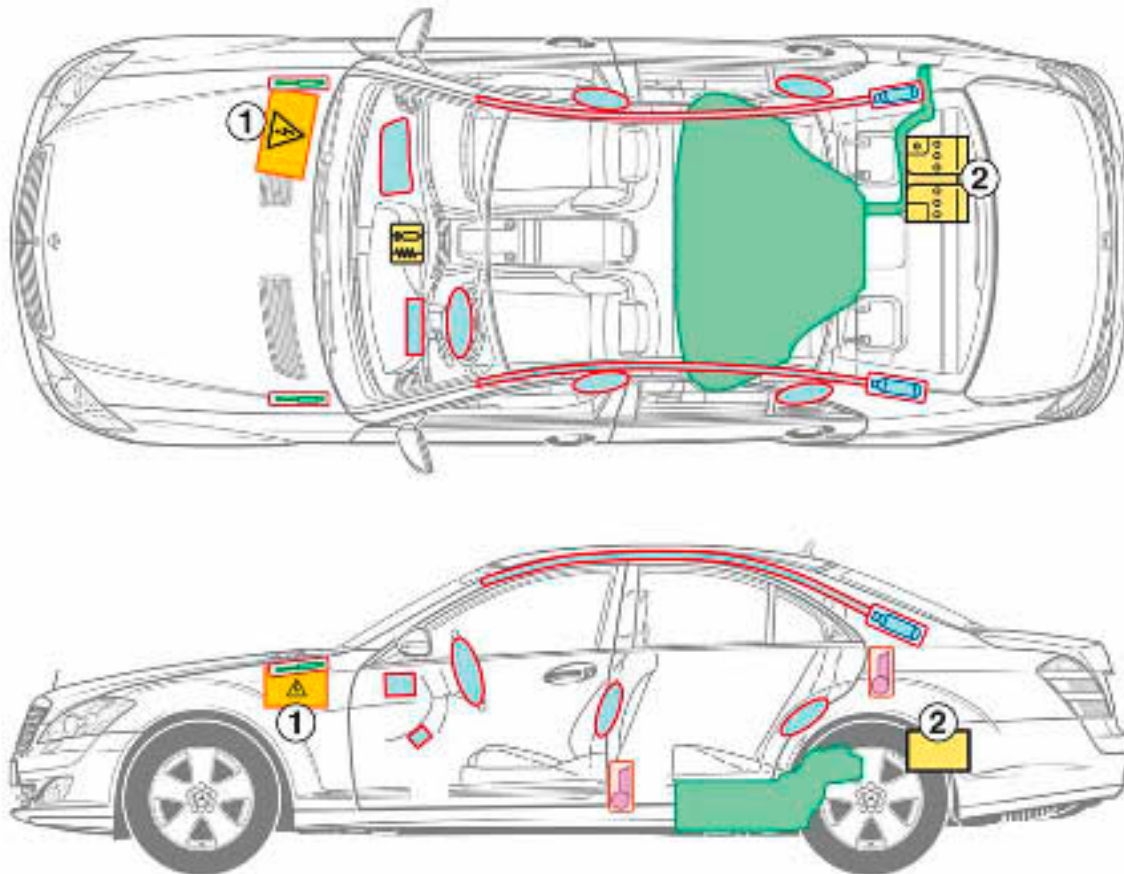

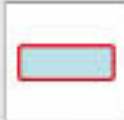

	Airbag		Body reinforcement		Control unit
	Gas generator		High-voltage components		Battery
	Emergency tensioning retractor		Gas-filled strut		Fuel tank

**S-Class HYBRID**  
(model 221)



- 1 High-voltage battery
- 2 12 V battery

**Legend**

	Airbag		Body reinforcement		Control unit
	Gas generator		High-voltage components		Battery
	Emergency tensioning retractor		Gas-filled strut		Fuel tank

smart fortwo

smart fortwo  
coupé  
electric drive  
(model 451)

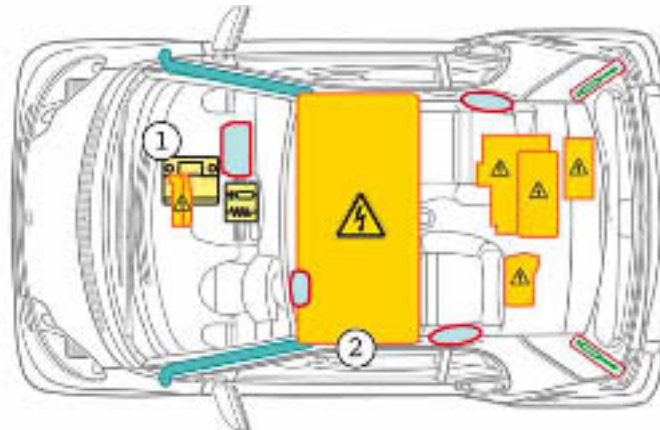

- 1 12 V battery
- 2 High-voltage battery

Legend



Airbag



Body reinforcement



Control unit



Gas generator



Roll-over protection



Battery



Emergency tensioning retractor



Gas-filled strut



High-voltage components